

STAINLESS STEEL STANDARD SUCTION
W/ (2) 2-1/2" FIRE GRADE VALVES
W/ CAP & CHAIN

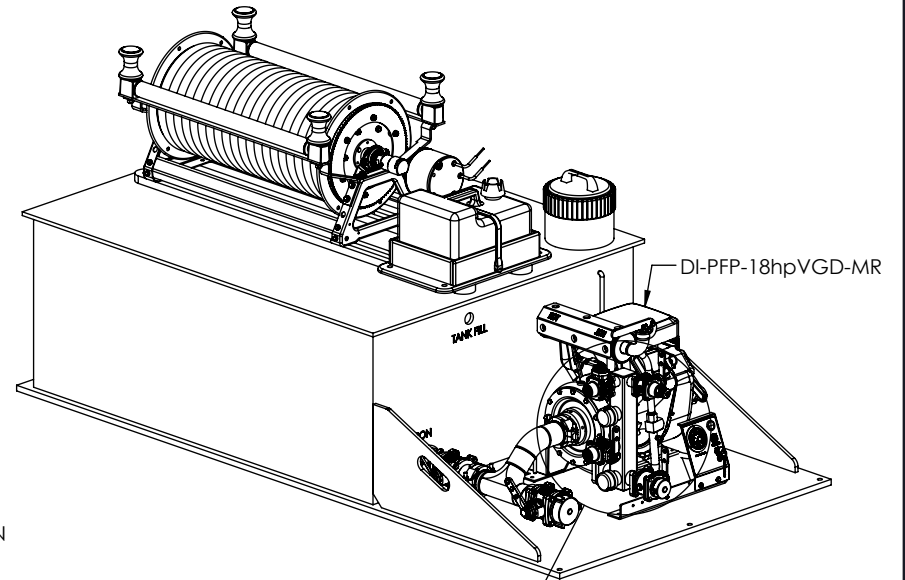

ELECTRIC REWIND HOSE REEL
W/ 3 WAY ROLLERS
W/ 1" x 150' RUBBER HOSE
MODEL: EF4038-17-18-RT

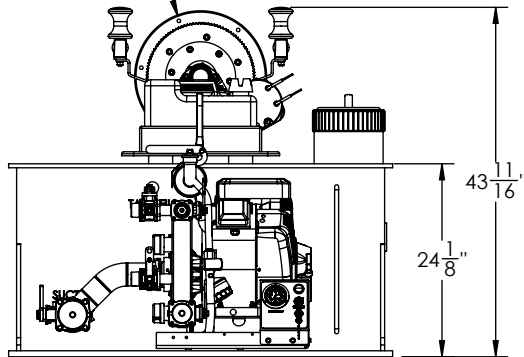

STAINLESS STEEL MANIFOLD

1" FIRE GRADE VALVE
TANK FILL

1-1/2" NPT-M NIPPLE
W/ CAP

1" FIRE GRADE VALVE
W/ 3/4" REDUCER GARDEN HOSE
W/ CAP & CHAIN
SERVICE LINE

1" FIRE GRADE VALVE
HOSE REEL

1-1/2" NPT-M NIPPLE
W/ CAP

1-1/2" FIRE GRADE VALVE
W/ CHROME CAP & CHAIN
SERVICE LINE

REV.	DATE	BY
------	------	----

	TITLE : NAFECO		APPROXIMATE DRY WEIGHT	QUOTE #	WARNING THIS DOCUMENT REMAINS THE PROPERTY OF C.E.T. FIRE PUMPS MFG. ALL REPRODUCTION WITHOUT WRITTEN AGREEMENT FROM C.E.T. FIRE PUMPS MFG IS TOTALLY PROHIBITED.
	250 U.S. GAL. WATER	- U.S. GAL. F.C.	- Lbs	25448	
No: DP-7315-0701	TANK TYPE	CREATED	APPROXIMATE WET WEIGHT	OPP #	APPROVED BY _____ APPROVED DATE _____
	S	BY: M.V. DATE: 2023-02-21	- Lbs	19790	

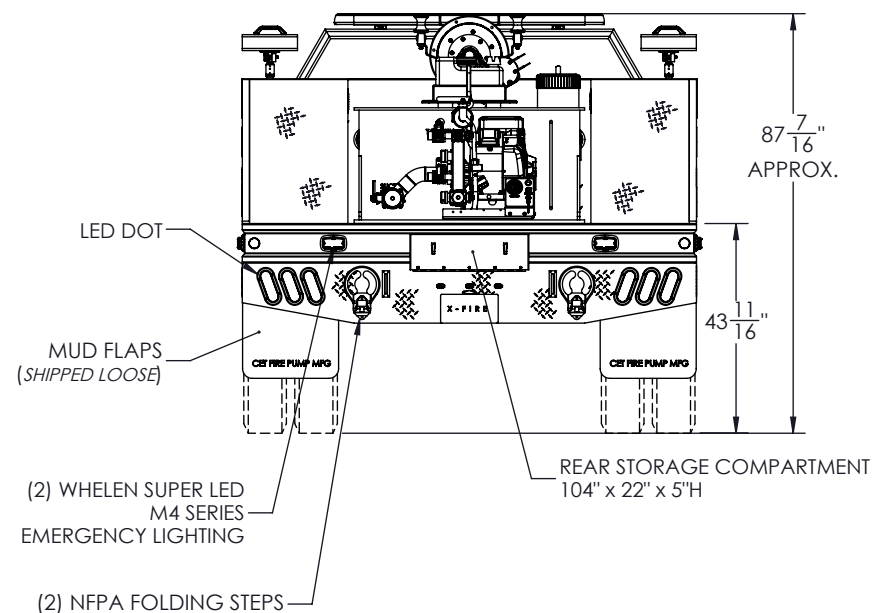
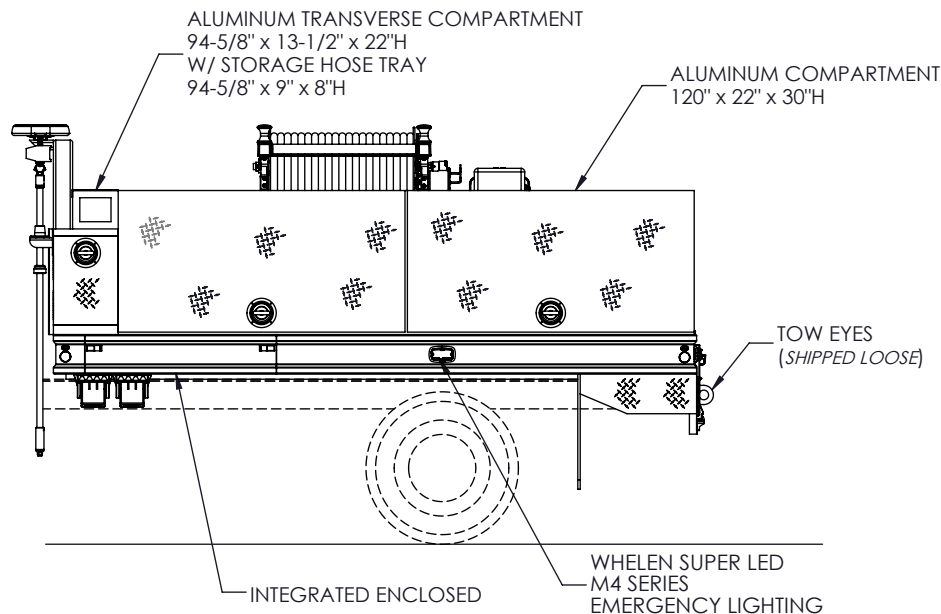
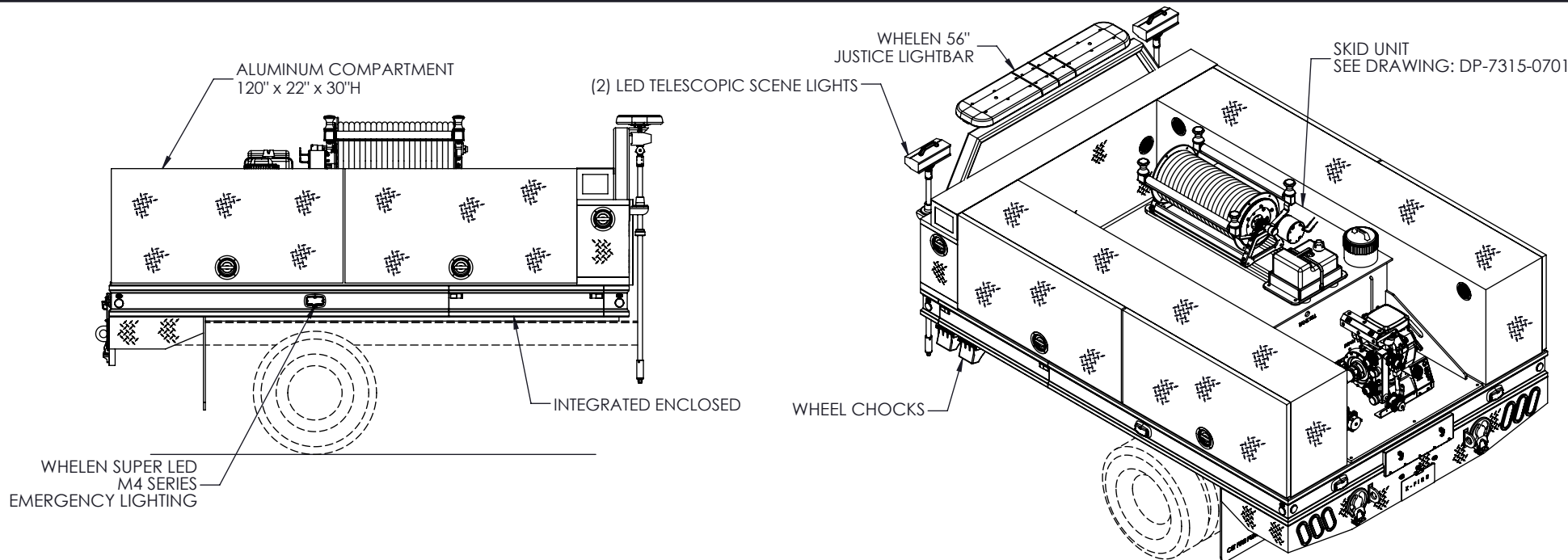

CREATED
BY: M.V.
DATE: 2023-02-21

VERIFIED
BY: M.V.
DATE: 2023-02-21

TITLE : **NAFECO**
C.E.T. GLIDER KIT

No: **FA-1969-0701**

WARNING

THIS DOCUMENT REMAINS THE PROPERTY OF C.E.T. FIRE PUMPS MFG.

ALL REPRODUCTION WITHOUT WRITTEN AGREEMENT FROM C.E.T. FIRE PUMPS MFG IS TOTALLY PROHIBITED.

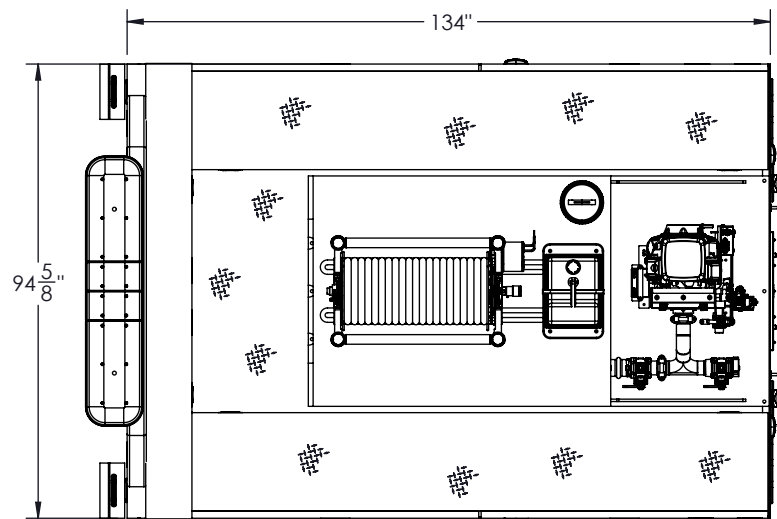

CHASSIS CAB
(SUPPLY BY CUSTOMER)

EXTERIOR WIDTH
OF FRAME RAILS
34-1/4"

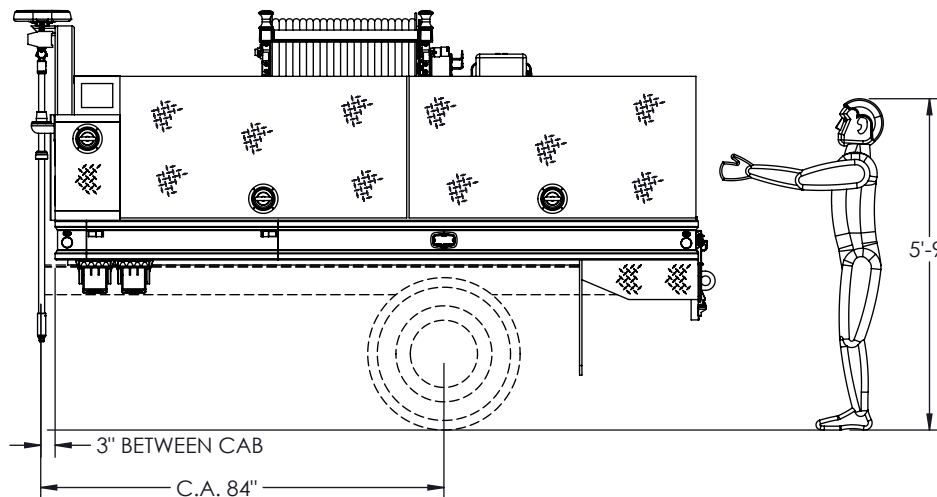

CREATED
BY: M.V.
DATE: 2023-02-21

VERIFIED
BY: M.V.
DATE: 2023-02-21

TITLE : NAFECO
C.E.T. GLIDER KIT

No: FA-1969-0701

WARNING

THIS DOCUMENT REMAINS THE PROPERTY OF C.E.T. FIRE PUMPS MFG.

ALL REPRODUCTION WITHOUT WRITTEN AGREEMENT FROM C.E.T. FIRE PUMPS MFG IS TOTALLY PROHIBITED.